

Exhibit A-7.VII

- San Diego Region of Orange County Interim Hydromodification Control Requirements





**IMPLEMENTATION OF INTERIM  
HYDROMODIFICATION CONTROL  
REQUIREMENTS IN THE SAN DIEGO REGION  
(SOUTH ORANGE COUNTY)**

Customer Service  
714-667-8888

[www.ocplanning.net](http://www.ocplanning.net)

County of Orange

***EFFECTIVE DECEMBER 16, 2010***

**ALL “PRIORITY” PROJECTS IN THE  
SAN DIEGO REGIONAL WATER QUALITY CONTROL  
BOARD REGION (SOUTH ORANGE COUNTY)  
WILL BE REQUIRED TO MEET  
“INTERIM HYDROMODIFICATION CONTROL REQUIREMENTS”**

Pursuant to the Municipal Separate Storm Sewer System Permit (Order No. R9-2009-0002), issued to the County of Orange and cities of south Orange County by the San Diego Regional Water Quality Control Board (“Regional Board”), all non-exempt “Priority” development projects must meet interim hydromodification control requirements effective December 16, 2010. Projects without an approved Water Quality Management Plan (WQMP) by this effective date will be required to match the post-construction hydrologic conditions of the project to the pre-development (naturally occurring) conditions through on-site engineered hydromodification controls.

To determine if a project must meet the Interim Hydromodification Control (IHC) Requirements, please follow these steps:

1. Use the attached checklist (Table 7.II-1) to determine if the proposed project in the San Diego Region of Orange County is a “Priority” or “Non-Priority” project. All “Non-Priority” projects are exempt from meeting IHC Requirements.
2. If the project meets the definition of “Priority,” use the following additional criteria to determine if the proposed project is exempt from meeting the IHC Requirements. “Priority” projects are exempt where the project discharges:
  - (a) stormwater runoff into underground storm drains discharging directly to bays or the ocean, or
  - (b) stormwater runoff into conveyance channels whose bed and bank are concrete lined all the way from the point of discharge to ocean waters, enclosed bays, estuaries, or water storage reservoirs and lakes.

All “Priority” projects that do not meet one of the exemption criteria must meet IHC Requirements. To meet these requirements, the WQMP for the project must include data regarding pre- and post-construction flow rates and the on-site engineered hydromodification controls must be sized to ensure that post-construction runoff does not exceed the baseline condition for flows up to the 10 year storm event. The County of Orange has prepared a “*Technical Guidance Document for the South Orange County Hydromodification Control BMP Sizing Tool*” as well as an Excel spreadsheet-based sizing tool to assist with the preparation of the WQMP for the project. Additional information can be found at the following links:

- San Diego Regional Water Quality Control Board, Order No. R9-2009-0002  
[http://www.ocwatersheds.com/Documents/San\\_Diego\\_Final\\_R9\\_2002\\_0001\\_with\\_Attachments.pdf](http://www.ocwatersheds.com/Documents/San_Diego_Final_R9_2002_0001_with_Attachments.pdf)
- CASQA New Development and Redevelopment Handbook  
<http://www.cabmphandbooks.com/development.asp>
- Los Angeles County Dept. of Public Works LID Manual  
[http://dpw.lacounty.gov/wmd/dsp\\_LowImpactDevelopment.cfm](http://dpw.lacounty.gov/wmd/dsp_LowImpactDevelopment.cfm)
- Ventura County Technical Guidance Manual for Stormwater Quality Control Measures  
<http://www.vcstormwater.org/technicalguidancemanual.html>

# TECHNICAL GUIDANCE DOCUMENT FOR THE SOUTH ORANGE COUNTY HYDROMODIFICATION CONTROL BMP SIZING TOOL



December 16, 2010



A COOPERATIVE PROJECT OF THE COUNTY OF  
ORANGE, THE CITIES OF ORANGE COUNTY, AND  
THE ORANGE COUNTY FLOOD CONTROL DISTRICT

## Table of Contents

<b>SECTION 1. INTRODUCTION .....</b>	<b>1-1</b>
<b>1.1. Applicability .....</b>	<b>1-1</b>
1.1.1. Priority Development Project Categories .....	1-1
1.1.2. Redevelopment Projects .....	1-2
1.1.3. Effective Date .....	1-3
<b>1.2. Interim Hydromodification Criteria.....</b>	<b>1-3</b>
1.2.1. Flow Duration Matching.....	1-4
1.2.2. Flow Range of Interest.....	1-4
1.2.3. Baseline Condition .....	1-4
1.2.4. Length of Rainfall Record .....	1-5
<b>1.3. Hydromodification Control BMPs .....</b>	<b>1-5</b>
1.3.1. Distributed/Onsite BMPs .....	1-5
1.3.2. Detention/Retention Basins .....	1-5
1.3.3. In-Stream Controls .....	1-6
<b>SECTION 2. BMP SIZING TOOL .....</b>	<b>2-1</b>
<b>2.1. Methodology .....</b>	<b>2-1</b>
<b>2.2. BMP Sizing Curves.....</b>	<b>2-6</b>
<b>2.3. Instructions for Spreadsheet Sizing Tool.....</b>	<b>2-8</b>
2.3.1. Inputs .....	2-8
2.3.2. Outputs .....	2-8
2.3.3. Modifying the BMP Design Configuration .....	2-9
<b>APPENDIX I. MODELING METHODOLOGY .....</b>	<b>A-1</b>

## List of Figures

FIGURE 1: BIORETENTION FACILITY SCHEMATIC.....	2-2
FIGURE 2: RECTANGULAR UNDERGROUND VAULT SCHEMATIC WITH OPEN BOTTOM .....	2-3
FIGURE 3: RECTANGULAR UNDERGROUND VAULT SCHEMATIC WITH CLOSED BOTTOM.....	2-4
FIGURE 4: PLANTER BOX SCHEMATIC.....	2-5
FIGURE 5. SIZING CHART FOR UNIT BMP FOOTPRINT AREA .....	2-6
FIGURE 6. SIZING CHART FOR UNIT BMP CAPTURE VOLUME .....	2-7
FIGURE 7. SIZING CHART FOR UNIT BMP TOTAL VOLUME.....	2-7

## **Section 1. Introduction**

This South Orange County Hydromodification Control BMP Sizing Tool Guidance Document has been developed by the County of Orange in cooperation with the incorporated Cities of South Orange County (Aliso Viejo, Dana Point, Laguna Beach, Laguna Hills, Laguna Niguel, Laguna Woods, Lake Forest, Mission Viejo, Rancho Santa Margarita, San Clemente, and San Juan Capistrano) to aid agency staff and project proponents with addressing the Interim Hydromodification Criteria in the Fourth Term South Orange County MS4 Permit (Order [R9-2009-0002](#)). This document serves as the technical resource companion to the Hydromodification Control BMP Sizing Tool (Sizing Tool - South OC Interim Hydromod Criteria v1.xlsx).

### **1.1. Applicability**

Priority Development Projects subject to the Interim Hydromodification Criteria are described below (see also [R9-2009-0002](#) Section F.1.d.)

#### **1.1.1. Priority Development Project Categories**

Projects in the following categories are considered Priority Development Projects. Where a new development project feature, such as a parking lot, falls into a Priority Development Project category, the entire project footprint is subject to the Interim Hydromodification Criteria.

1. **New development projects that create 10,000 square feet or more of impervious surfaces** (collectively over the entire project site) including commercial, industrial, residential, mixed-use, and public projects. This category includes development projects on public or private land which fall under the planning and building authority of the Copermittees.
2. **Automotive repair shops.** This category is defined as a facility that is categorized in any one of the following Standard Industrial Classification (SIC) codes: 5013, 5014, 5541, 7532-7534, or 7536-7539.
3. **Restaurants.** This category is defined as a facility that sells prepared foods and drinks for consumption, including stationary lunch counters and refreshment stands selling prepared foods and drinks for immediate consumption (SIC code 5812), where the land area for development is greater than 5,000 square feet. Restaurants where land development is less than 5,000 square feet are not subject to the Interim Hydromodification Criteria.
4. **All hillside development greater than 5,000 square feet.** This category is defined as any development which creates 5,000 square feet of impervious surface which is located in an area with known erosive soil conditions, where the development will grade on any natural slope that is twenty-five percent or greater.

5. **Environmentally Sensitive Areas (ESAs)**<sup>1</sup>. All development located within or directly adjacent to or discharging directly to an ESA (where discharges from the development or redevelopment will enter receiving waters within the ESA), which either creates 2,500 square feet of impervious surface on a proposed project site or increases the area of imperviousness of a proposed project site to 10 percent or more of its naturally occurring condition. “Directly adjacent” means situated within 200 feet of the ESA. “Discharging directly to” means outflow from a drainage conveyance system that is composed entirely of flows from the subject development or redevelopment site, and not commingled with flows from adjacent lands.
6. **Parking lots 5,000 square feet or more or with 15 or more parking spaces and potentially exposed to runoff**. Parking lot is defined as a land area or facility for the temporary parking or storage of motor vehicles used personally, for business, or for commerce.
7. **Street, roads, highways, and freeways**. This category includes any paved surface that is 5,000 square feet or greater used for the transportation of automobiles, trucks, motorcycles, and other vehicles.
8. **Retail Gasoline Outlets (RGOs)**. This category includes RGOs that meet the following criteria: (a) 5,000 square feet or more or (b) a projected Average Daily Traffic (ADT) of 100 or more vehicles per day.
9. **One acre threshold**. Effective December 16, 2012, Priority Development Projects also includes all other pollutant-generating development projects<sup>2</sup> that result in the disturbance of one acre or more of land. As an alternative to this one-acre threshold, the Copermittees may collectively identify a different threshold, provided the Copermittees’ threshold is at least as inclusive of development projects as the one-acre threshold.

### **1.1.2. Redevelopment Projects**

Those redevelopment projects that create, add, or replace at least 5,000 square feet of impervious surfaces on an already developed site and the existing development and/or the redevelopment project falls under the project categories or locations listed in Section 1.1.1.

---

<sup>1</sup> Environmentally Sensitive Areas (ESAs) are areas that include but are not limited to all Clean Water Act Section 303(d) impaired water bodies; areas designated as Areas of Special Biological Significance by the State Water Resources Control Board (Water Quality Control Plan for the San Diego Basin (1994) and amendments); State Water Quality Protected Areas; water bodies designated with the RARE beneficial use by the State Water Resources Control Board (Water Quality Control Plan for the San Diego Basin (1994) and amendments); areas designated as preserves or their equivalent under the Natural Communities Conservation Program within the Cities and County of Orange; and any other equivalent environmentally sensitive areas which have been identified by the Copermittees.

<sup>2</sup> Pollutant generating development projects are those projects that generate pollutants at levels greater than natural background levels.

Where redevelopment results in an increase of less than 50 percent of the impervious surfaces of a previously existing development, and the existing development was not subject to SSMP requirements, the Interim Hydromodification Criteria applies only to the addition or replacement, and not to the entire development. Where redevelopment results in an increase of more than 50 percent of the impervious surfaces of a previously existing development, the Interim Hydromodification Criteria applies to the entire development.

### **1.1.3. Effective Date**

The Interim Hydromodification Criteria apply to all projects or phases of projects, unless, on December 16, 2010, the projects or project phases meet any one of the following conditions:

1. The project or phase has begun grading or construction activities; or
2. The local permitting authority determines that lawful prior approval rights for the project or project phase exist, whereby application of the Interim Hydromodification Criteria to the project is legally infeasible.

## **1.2. Interim Hydromodification Criteria**

Order No. R9-2009-0002 contains the following interim hydromodification control (IHC) requirement:

*Within one year of adoption of this Order, each Copermittee must ensure that all Priority Development Projects are implementing the following criteria by comparing the pre-development (naturally occurring) and post-project flow rates and durations using a continuous simulation hydrologic model such as US EPA's Hydrograph Simulation Program-Fortran (HSPF):*

- (a) For flow rates from 10 percent of the 2-year storm event to the 5 year storm event, the post-project peak flows shall not exceed predevelopment (naturally occurring) peak flows.*
- (b) For flow rates from the 5 year storm event to the 10 year storm event, the post-project peak flows may exceed pre-development (naturally occurring) flows by up to 10 percent for a 1-year frequency interval.*

*The interim hydromodification criteria do not apply to Priority Development Projects where the project discharges (1) storm water runoff into underground storm drains discharging directly to bays or the ocean, or (2) storm water runoff into conveyance channels whose bed and bank are concrete lined all the way from the point of discharge to ocean waters, enclosed bays, estuaries, or water storage reservoirs and lakes.*

*Within one year of adoption of this Order, each Copermittee must submit a signed, certification statement to the Regional Board verifying implementation of the interim hydromodification criteria.*

The following sections discuss some of the key concepts contained in the criteria and their relevance to preventing excessive stream erosion and sedimentation.

### **1.2.1. Flow Duration Matching**

A basic concept in hydromodification management control is to design hydromodification control BMPs such that runoff from a project does not exceed the baseline condition. The introduction of new or increasing impervious surfaces can increase both the magnitude and duration of runoff and it is these characteristics that the interim hydromodification criteria is intended to address. Moreover, the effect of increased runoff on stream channel erosion is not restricted to a specific flow rate (or design storm), but rather a range of flows are important. The concept of flow duration matching is to incorporate hydrologic controls such that the flows and their durations do not differ from the baseline case over some specified range of flows. Plots showing flow versus duration are referred to as “flow duration curves<sup>3</sup>.” The goal of the IHC is to integrate hydrologic controls into a proposed project such that the flow duration curve corresponding to the post-project condition agrees with the baseline condition curve over the range of flows of interest. When this is accomplished, runoff from the proposed development would not contribute additional erosive forces in the receiving stream channel.

### **1.2.2. Flow Range of Interest**

Geomorphic research has found that the most important range of flows, from the perspective of affecting channel form, are the relatively more frequent flows that are contained primarily within the active channel and not the rare, high magnitude flows. Flows which create shear stresses (forces) high enough to initiate sediment transport within the channel and which occur frequently enough to have influence over long-term stream morphology are considered “geomorphically-significant” flows. Sand bedded streams have lower critical shear stresses and are readily moved by increased flows, whereas channel materials that are larger, such as gravels and cobbles, and more cohesive, such as clays, are more resistant to being moved. The IHC calls for considering a range of flows extending from 10% of the 2-year peak flow (0.1Q<sub>2</sub>) to the 10-year peak flow (Q<sub>10</sub>)<sup>4</sup>.

### **1.2.3. Baseline Condition**

The baseline condition assumption depends on the requirements of the MS4 Permit. The baseline condition in the South Orange County MS4 Permit is the pre-development (naturally occurring) condition. This is equivalent to the most prominent naturally vegetated condition that existed prior to urbanization and agriculture in those portions of southern Orange County that are likely to be developed. For example, the oak grasslands habitat is one possible pre-development condition that might be adopted as part of the interim criteria.

---

<sup>3</sup> A flow duration curve is a plot of flow rate (y-axis) vs. the cumulative duration, or percentage of time, that a flow rate is exceeded in the simulation record (x-axis).

<sup>4</sup> Specifically, the South Orange County Interim Hydromodification Criteria requires that post-project peak flows not exceed pre-development flows up to Q<sub>5</sub>. For flow rates from Q<sub>5</sub> to Q<sub>10</sub>, post-project peak flows may exceed pre-development peak flows by up to 10 percent for a 1-year frequency interval.

#### **1.2.4. Length of Rainfall Record**

The IHC calls for the use of continuous hydrologic modeling to account for the response of channels to a range of flows, as described above. These types of models use a continuous rainfall record to predict project runoff. As a practical matter, the longer the rainfall record the better, but at a minimum, a rainfall record of at least 20 years with an hourly time interval of rainfall readings should be used. Upwards of 50 years is preferred if the data is available.

### **1.3. Hydromodification Control BMPs**

A variety of volume / flow management structural BMPs are available that utilize the following two basic principles:

- Detain runoff and release it in a controlled way that either mimics pre-development hydrograph or reduces flow durations to account for a reduction in sediment supply.
- Manage excess runoff volumes through one or more of the following pathways: infiltration, evapotranspiration, storage and use, discharge at a rate below the critical rate for adverse impact, or discharge downstream to a non-susceptible water body.

#### **1.3.1. Distributed/Onsite BMPs**

Distributed BMPs are small scale facilities, typically treating runoff from less than ten acres. These types of facilities include, but are not limited to, infiltration trenches, bioretention areas, permeable pavement, green roofs, cisterns, and underground vaults or pipes. These types of facilities may also help to achieve the MS4 Permit's LID performance standard.

#### **1.3.2. Detention/Retention Basins**

Detention/retention basins are stormwater management facilities that are designed to detain and infiltrate runoff from one or multiple projects or project areas. These basins are typically shallow with flat, vegetated bottoms. Detention/retention basins can be constructed by either excavating a depression or building a berm to create above ground storage, such that runoff can drain into the basin by gravity. Runoff is stored in the basin as well as in the pore spaces of the surface soils. Pretreatment BMPs such as swales, filter strips, and sedimentation forebays minimize fine sediment loading to the basins, thereby reducing maintenance frequencies.

Detention/retention basins for hydromodification management incorporate outlet structures designed for flow duration control. These basins can also be designed to support flood control and water quality treatment objectives in addition to hydromodification. If underlying soils are not suitable for infiltration, the basin may be designed for flow detention only, with alternative practices to manage increased volumes, such as storage and use, discharge at a rate below the critical rate for adverse impacts, or discharge to a non-susceptible water body.

Detention/retention basins should be designed to receive flows from developed areas only, for both design optimization as well as to avoid intercepting coarse sediments from open spaces

that should ideally be passed through to the stream channel. Reduction in coarse sediment loads contributes to channel instability.

### **1.3.3. In-Stream Controls**

Hydromodification management can also be achieved by in-stream controls, including drop structures, bed and bank reinforcement, and grade control structures.

#### ***Drop Structures***

Drop structures are designed to reduce the channel slope, thereby reducing the shear stresses generated by stream flows. These controls can be incorporated as natural appearing rock structures with a step-pool design which allows drop energy to be dissipated in the pools while providing a reduced longitudinal slope between structures.

#### ***Grade Control Structures***

Grade control structures are designed to maintain the existing channel slope while allowing for minor amounts of local scour. These control measures are often buried and would entail a narrow trench across the width of the stream backfilled with concrete or similar material, as well as the creation of a “plunge pool” feature on the downstream side of the sill by placing boulders and vegetation. A grade control option provides a reduced footprint and impact compared to drop structures, which are designed to alter the channel slope.

#### ***Bed and Bank Reinforcement***

Channel reinforcement serves to increase bed and bank resistance to stream flows. In addition to conventional techniques such as riprap and concrete, a number of vegetated approaches are increasingly utilized, including products such as vegetated reinforcement mats. This technology provides erosion control with an open-weave material that stabilizes bed and bank surfaces and allows for re-establishment of native plants, which serves to further increase channel stability.

## **Section 2. BMP Sizing Tool**

Hydrologic modeling was used to develop a series of simplified sizing charts and a sizing spreadsheet tool to standardize the sizing of four types of BMPs for hydromodification control. The sizing tool allows project proponents to easily determine the necessary BMP storage volume and footprint area for flow duration control as a function of the proposed level of imperviousness and the onsite Hydrologic Soil Group<sup>5</sup> (A/B or C/D). The sizing tool takes into account a reasonable range of design and environmental conditions. In addition, because the BMP footprint is expressed as a percentage of the project catchment area, the BMPs can range in size. This flexibility allows a project proponent to strategically situate many small scale distributed facilities or fewer larger facilities depending on site constraints.

Please see the OC Public Works/OC Planning Website at the following link for access to the Excel spreadsheet-based sizing tool: [http://www.ocplanning.net/Documents/xls/BMP\\_SizingToo.xls](http://www.ocplanning.net/Documents/xls/BMP_SizingToo.xls)

The four BMP types incorporated in the sizing tool are: (1) a bioretention facility, (2) a rectangular underground vault with an open bottom, (3) a rectangular underground vault with a closed bottom, and (4) a planter box. The bioretention facility and open-bottomed vault allow for infiltration into the underlying soils and the closed bottom vault and planter boxes do not. Figures 1 through 4 illustrate the BMP configurations that were modeled to develop the sizing tool.

### **2.1. Methodology**

For each BMP type, ten continuous hydrologic simulations using US EPA's Storm Water Management Model (SWMM) were conducted with a combination of two soil types (A/B and C/D) and five imperviousness values (1%, 25%, 50%, 75%, and 100%). The simulations were performed on a generic catchment area in order to generate long-term flow records. A generic 1 acre catchment area was selected to size the bioretention facility, a 10 acre catchment area was used to size the underground vaults, and a ¼ acre catchment area was used to size the planter box<sup>6</sup>. The 1% imperviousness simulation represents the baseline (pre-development) flow records and the 25%, 50%, 75%, and 100% imperviousness simulations represent a range of post-development conditions. The BMPs were sized by iteratively adjusting the BMP footprint until flow duration control was achieved with the minimum BMP footprint.

Appendix I provides more detail on the modeling approach.

---

<sup>5</sup> Based on NRCS soil survey data, approximately 47% of South Orange County is considered Type D soil, 37% is Type C, 13% is Type B, and 3% is Type A.

<sup>6</sup> These areas were used because they are between the expected lower and upper limits of catchment areas likely to drain into each BMP type. Bioretention facilities were expected to be applied to catchments ranging between 5,000 square feet (0.11 acres) to 5 acres. Underground vaults were expected to be applied to catchments ranging between 1 acre and 50 acres. Planter boxes were expected to be applied to catchments less than 1 acre.

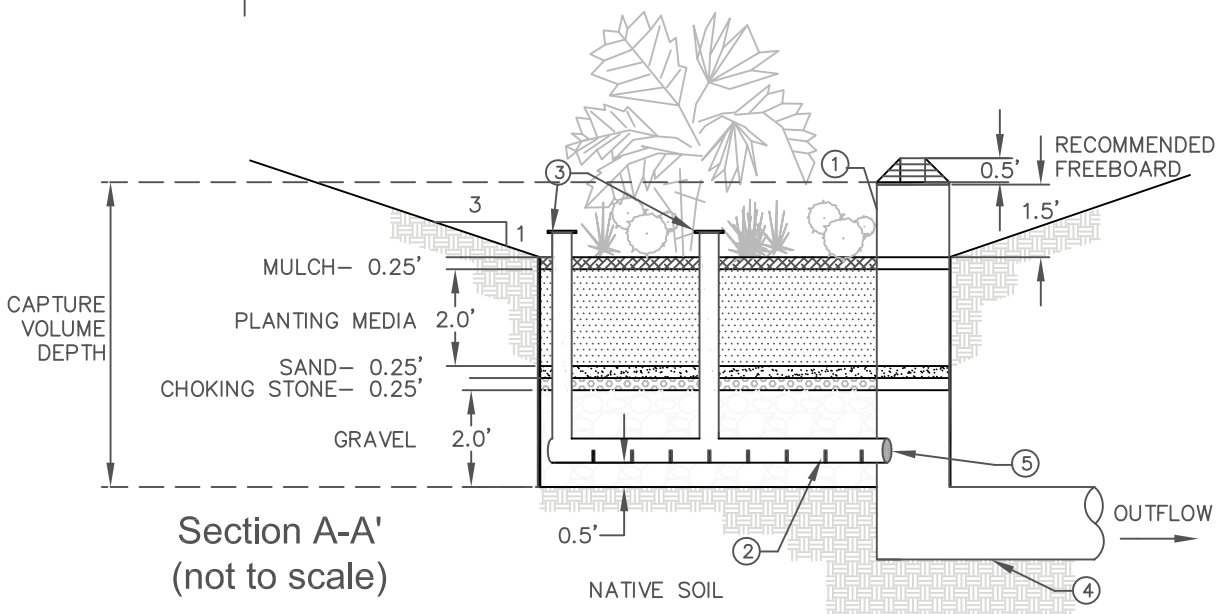
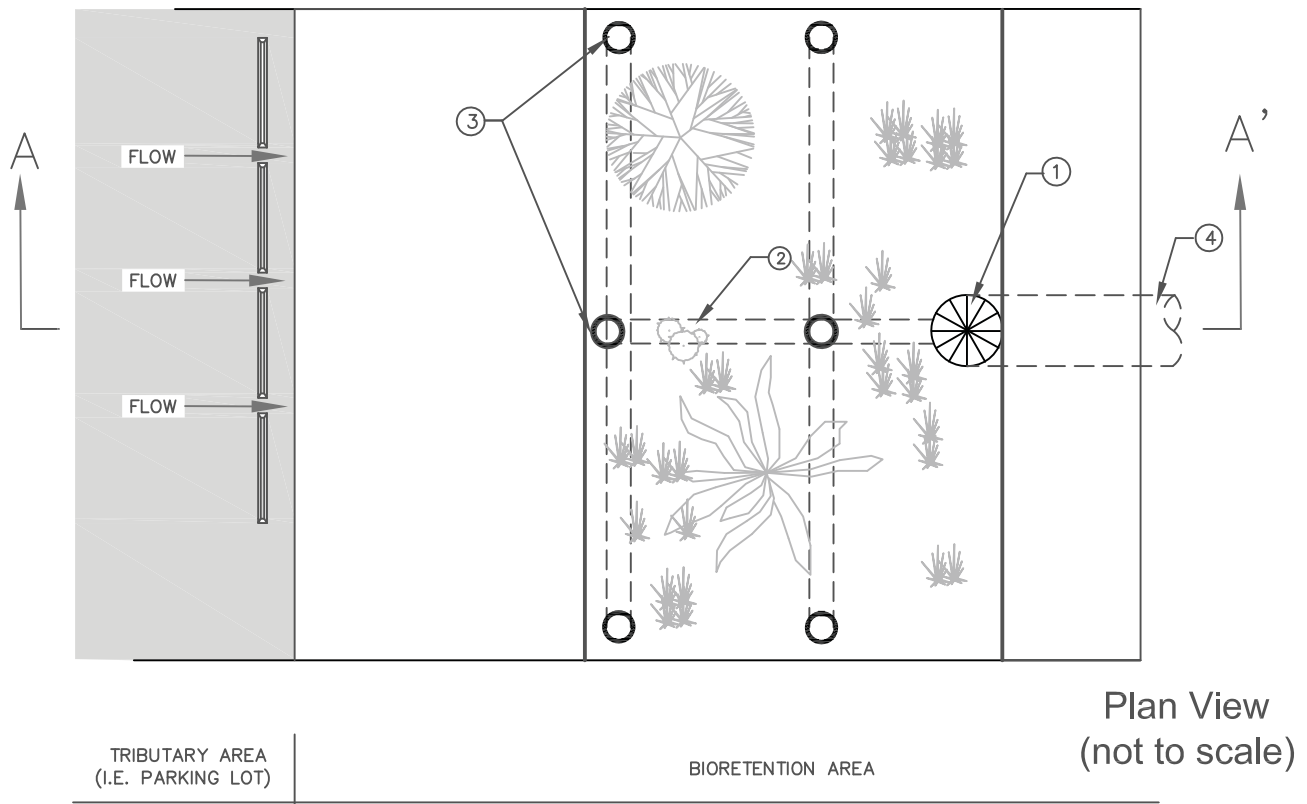

NOTES:

- ① OVERFLOW DEVICE WITH WEIR LENGTH SIZED TO CONVEY THE DESIGN DISCHARGE AS REQUIRED BY THE ORANGE COUNTY LOCAL DRAINAGE MANUAL AND HYDROLOGY MANUAL OR THE LOCAL PERMITTING AUTHORITY
- ② SLOTTED 6" MIN PVC PIPE UNDERDRAIN (C/D SOILS ONLY)
- ③ 6" MIN PVC PIPE CLEANOUT (C/D SOILS ONLY)
- ④ OUTLET PIPE SIZED TO CONVEY THE DESIGN DISCHARGE AS REQUIRED BY THE ORANGE COUNTY LOCAL DRAINAGE MANUAL AND HYDROLOGY MANUAL OR THE LOCAL PERMITTING AUTHORITY
- ⑤ BLIND FLANGE AT END OF SLOTTED UNDERDRAIN DRILLED TO SPECIFIC ORIFICE DIAMETER (C/D SOILS ONLY)

<b>Bioretention Facility</b>

Figure 1. Bioretention Facility Schematic

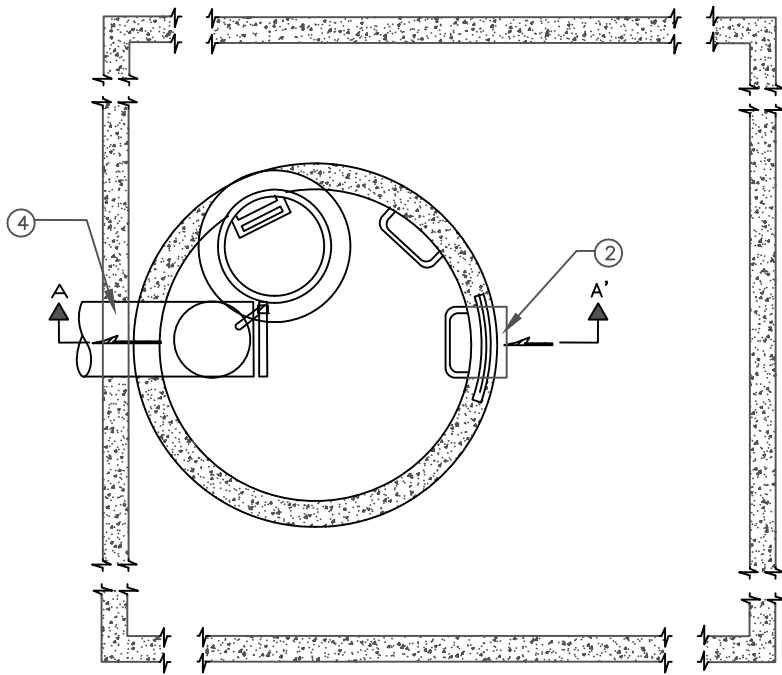

Underground Vault Outlet  
Plan View

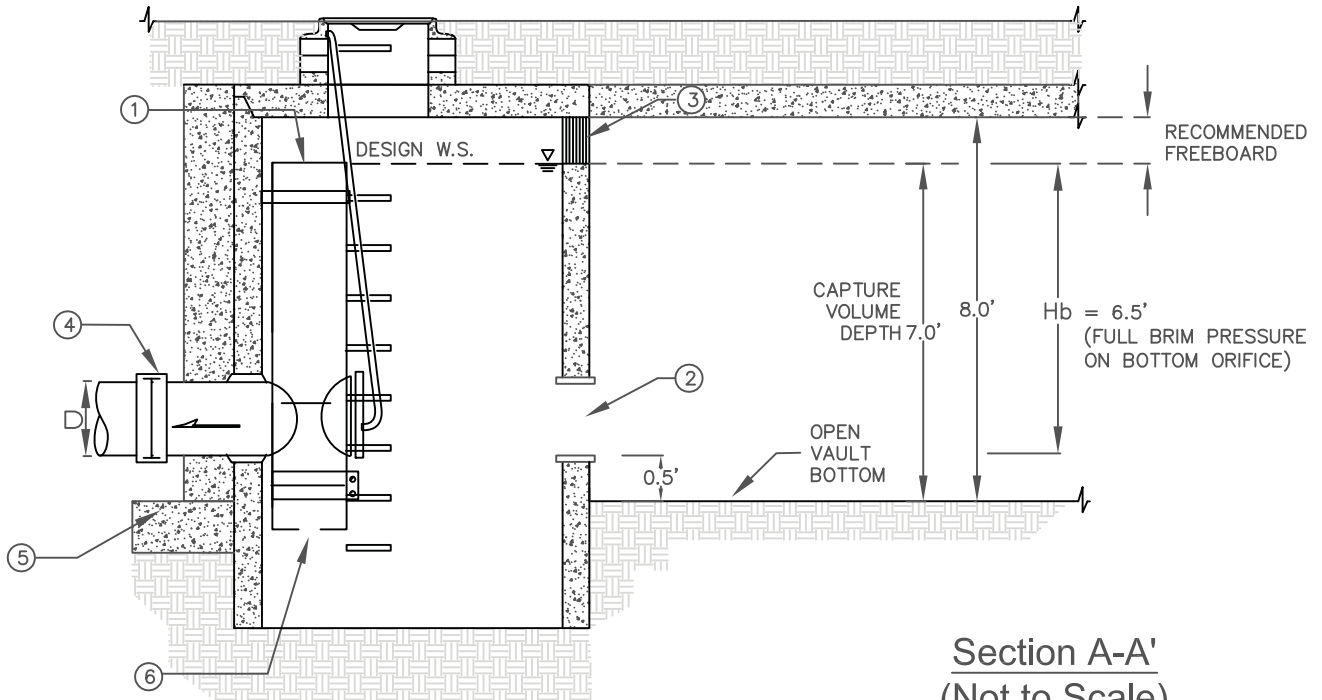

Section A-A'  
(Not to Scale)

NOTES:

- ① OVERFLOW DEVICE WITH WEIR LENGTH SIZED TO CONVEY THE DESIGN DISCHARGE AS REQUIRED BY THE ORANGE COUNTY LOCAL DRAINAGE MANUAL AND HYDROLOGY MANUAL OR THE LOCAL PERMITTING AUTHORITY
- ② PRIMARY INLET
- ③ SECONDARY INLET
- ④ OUTLET PIPE SIZED TO CONVEY THE DESIGN DISCHARGE AS REQUIRED BY THE ORANGE COUNTY LOCAL DRAINAGE MANUAL AND HYDROLOGY MANUAL OR THE LOCAL PERMITTING AUTHORITY
- ⑤ FOOTING FOUNDATION TO PROMOTE INFILTRATION WITHIN THE VAULT
- ⑥ RESTRICTOR PLATE WITH ORIFICE DIAMETER (C/D SOILS ONLY)

Vault- Open Bottom	

Figure 2 Open-Bottom Underground Vault Schematic

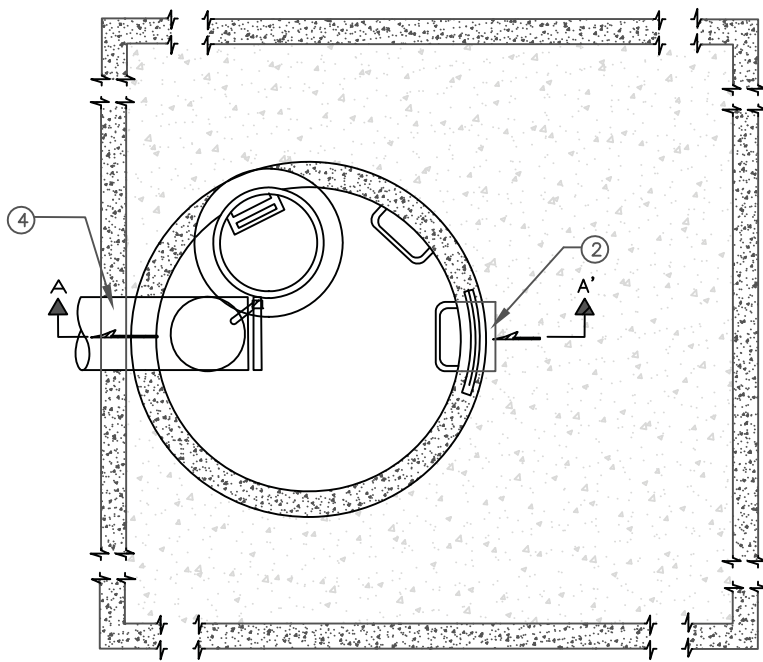

Underground Vault Outlet  
Plan View

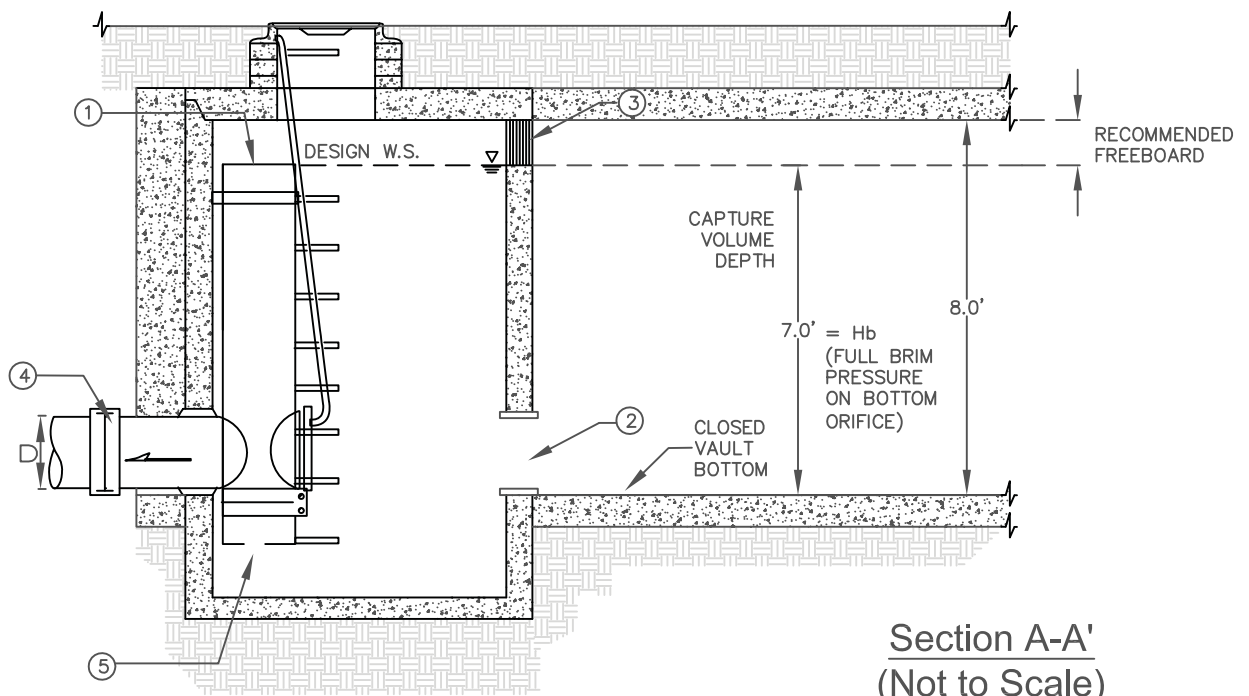

Section A-A'  
(Not to Scale)

NOTES:

- ① OVERFLOW DEVICE WITH WEIR LENGTH SIZED TO CONVEY THE DESIGN DISCHARGE AS REQUIRED BY THE ORANGE COUNTY LOCAL DRAINAGE MANUAL AND HYDROLOGY MANUAL OR THE LOCAL PERMITTING AUTHORITY
- ② PRIMARY INLET
- ③ SECONDARY INLET
- ④ OUTLET PIPE SIZED TO CONVEY THE DESIGN DISCHARGE AS REQUIRED BY THE ORANGE COUNTY LOCAL DRAINAGE MANUAL AND HYDROLOGY MANUAL OR THE LOCAL PERMITTING AUTHORITY
- ⑤ RESTRICTOR PLATE WITH ORIFICE DIAMETER

Vault- Closed Bottom	

Figure 3. Closed-Bottom Underground Vault Schematic

**Planter Box  
Plan View**

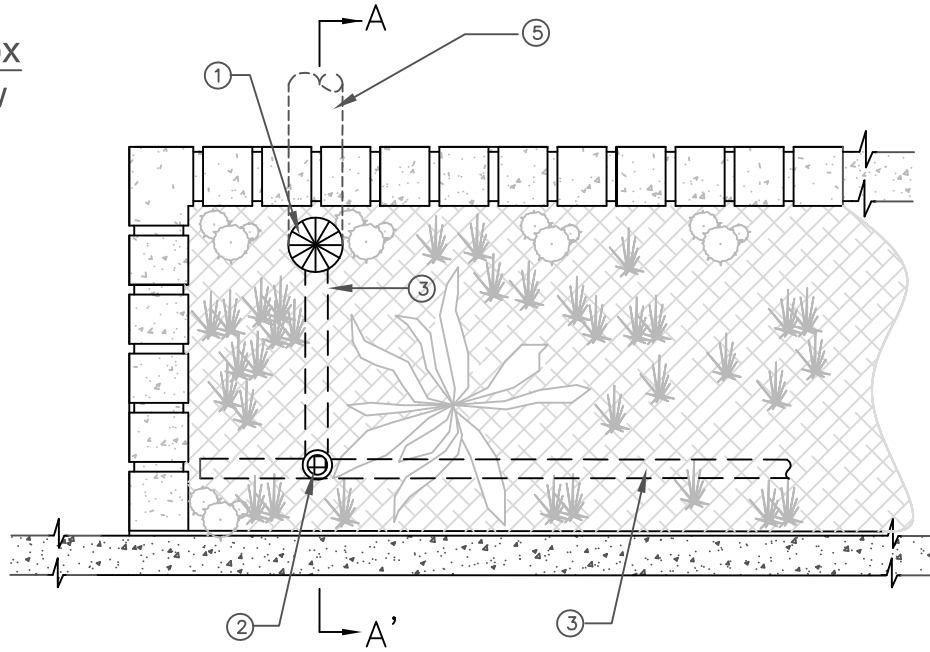

**Section A-A'  
(Not to Scale)**

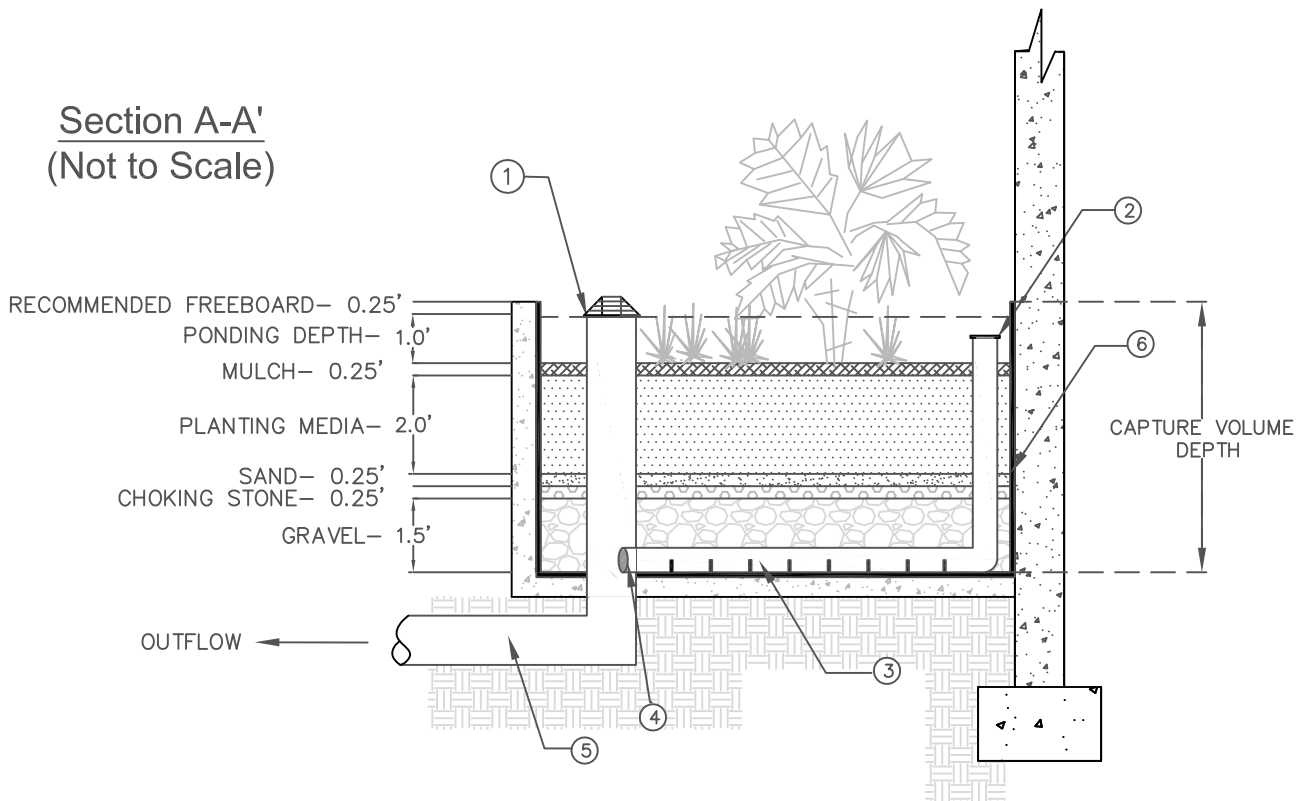

**NOTES:**

- ① OVERFLOW DEVICE WITH WEIR LENGTH SIZED TO CONVEY THE DESIGN DISCHARGE AS REQUIRED BY THE ORANGE COUNTY LOCAL DRAINAGE MANUAL AND HYDROLOGY MANUAL OR THE LOCAL PERMITTING AUTHORITY
- ② 6" MIN PVC PIPE CLEANOUT
- ③ SLOTTED 6" MIN PVC PIPE UNDERDRAIN
- ④ BLIND FLANGE AT END OF SLOTTED UNDERDRAIN DRILLED TO SPECIFIC ORIFICE DIAMETER
- ⑤ OUTLET PIPE SIZED TO CONVEY THE DESIGN DISCHARGE AS REQUIRED BY THE ORANGE COUNTY LOCAL DRAINAGE MANUAL AND HYDROLOGY MANUAL OR THE LOCAL PERMITTING AUTHORITY
- ⑥ WATERPROOF BARRIER

<p><b>Planter Box</b></p>	

Figure 4. Planter Box Schematic

## 2.2. BMP Sizing Curves

Figure 5 below shows the resulting BMP footprint area, Figure 6 shows the BMP capture volume, and Figure 7 shows the total volume (including the suggested freeboard volumes illustrated on Figures 1 to 4). The BMP footprint is defined as the plan view area at the overflow weir crest elevation and is expressed as a percentage of the tributary catchment area. The BMP capture volume is defined as the storage volume in the BMP below the overflow crest elevation and has units of watershed inches. The total BMP volume is defined as the storage volume contained beneath the suggested freeboard elevation, also expressed in watershed inches. Regression lines are provided on the charts so that the unit footprint area and storage volume can be interpolated for any value of imperviousness.

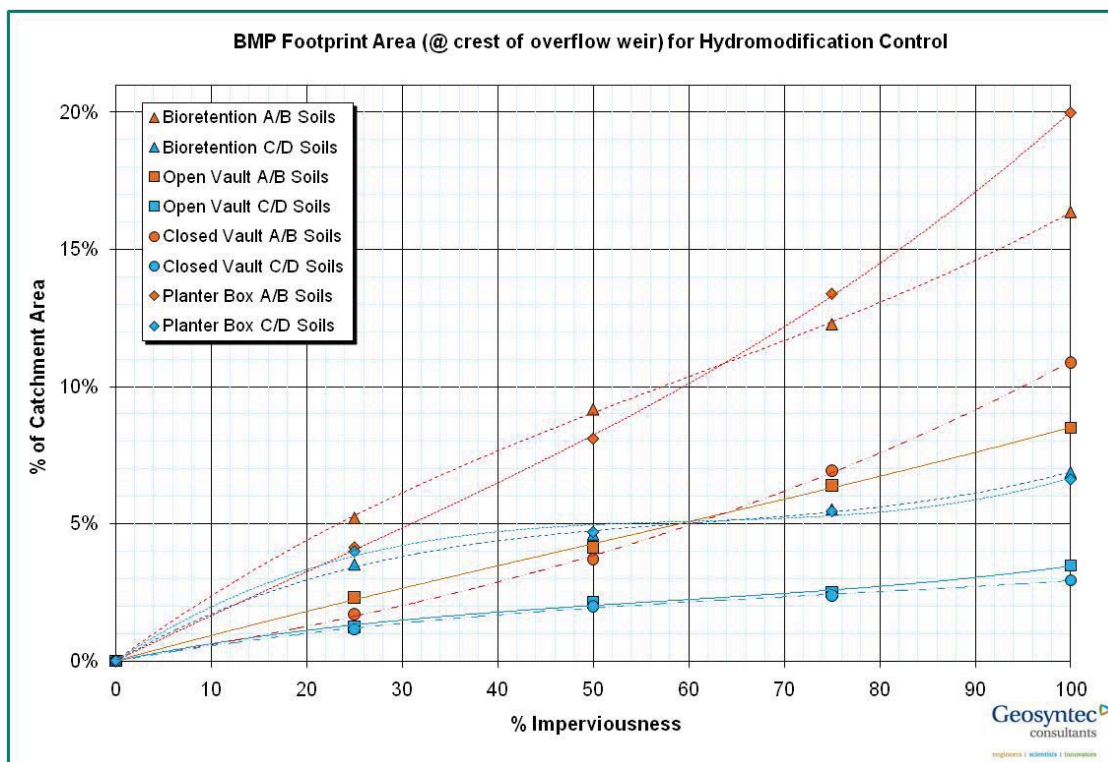

Figure 5. Sizing Chart for Unit BMP Footprint Area

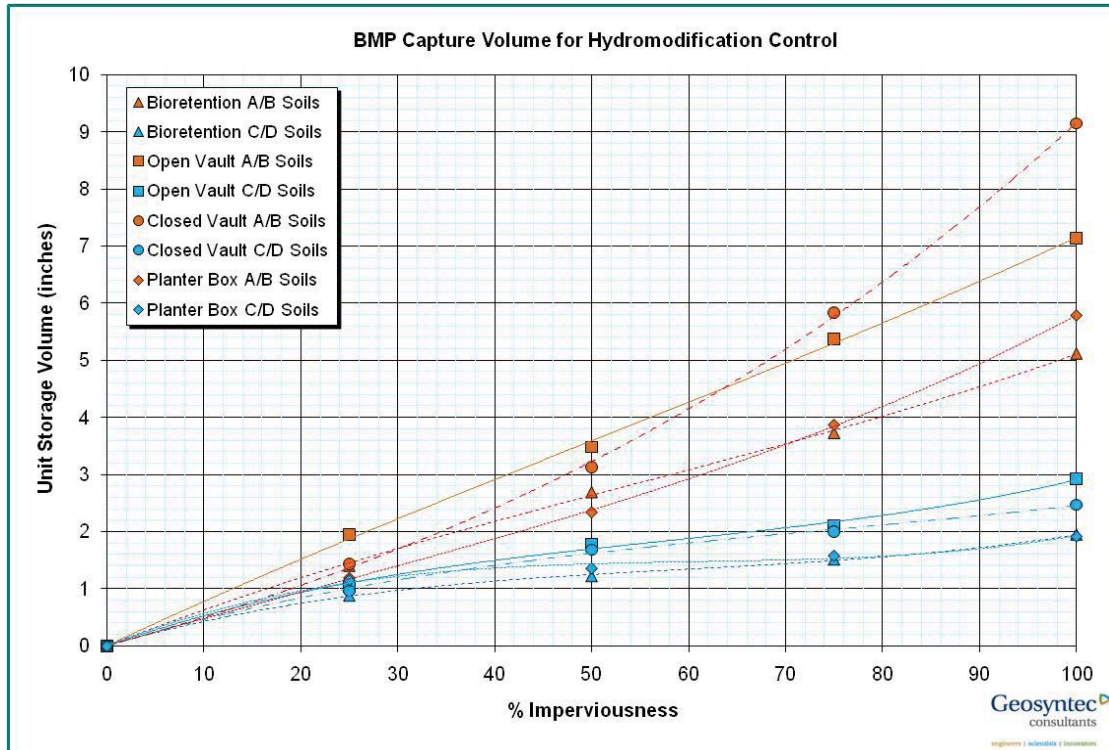

Figure 6. Sizing Chart for Unit BMP Capture Volume

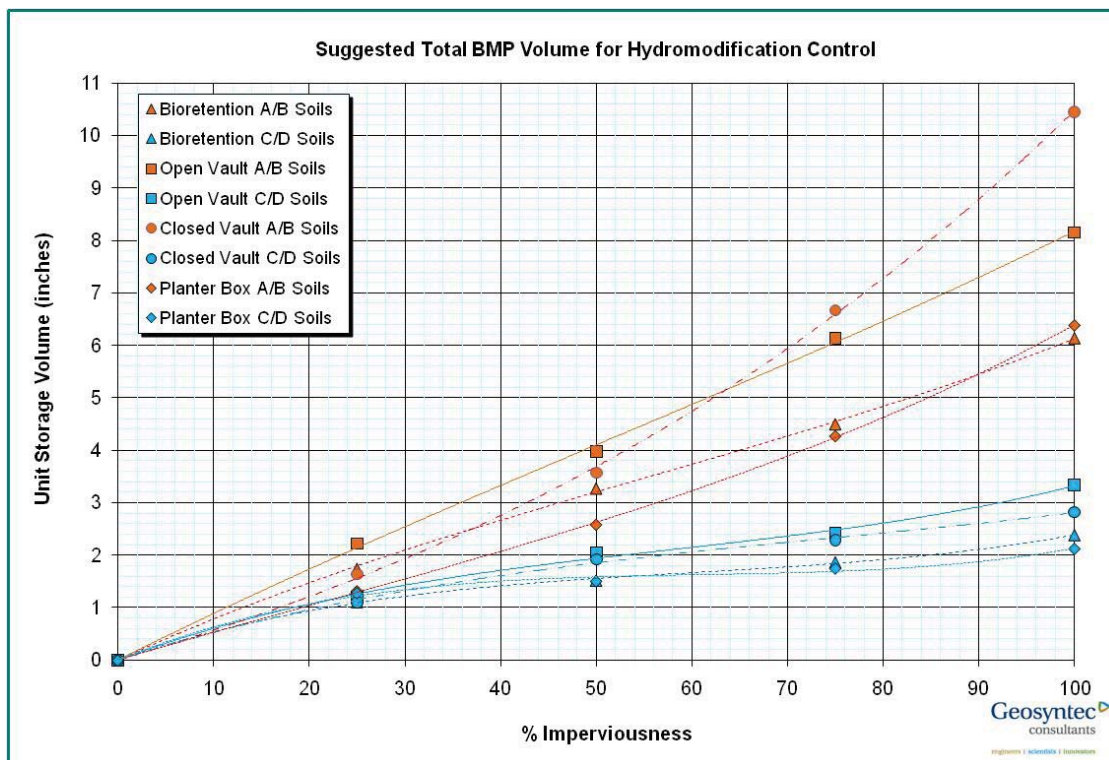

Figure 7. Sizing Chart for Unit BMP Total Volume

## **2.3. Instructions for Spreadsheet Sizing Tool**

The South Orange County Hydromodification Control BMP Sizing Tool spreadsheet is structured so that inputs entered in the “master” worksheet generate the necessary parameters for sizing BMPs to meet the IHC. The inputs and outputs to the spreadsheet master worksheet are described below, as well as allowable modifications to the design configurations illustrated in Figures 1 through 4 that would comply with the IHC.

### **2.3.1. Inputs**

**Catchment ID** is a label that helps to organize different drainage areas within a Priority Development Project. The user can choose any naming convention they wish for the Catchment ID.

**BMP Type** must be selected from a pull-down menu of the four BMP types included in the tool.

**Soil Type** must be selected from a pull-down menu as “A/B” if the catchment is a Type A or B soil or “C/D” if the catchment is a Type C or D soil<sup>7</sup>.

**Catchment Area** is the acreage tributary to the BMP being sized. For a bioretention facility or planter box, the catchment area must include the area of the BMP itself. This is not the case for the underground vault BMPs because precipitation does not fall directly on the BMPs.

**Imperviousness** is the proportion of impervious surface area in the project catchment. Impervious areas include, but are not limited to, rooftops, asphalt pavement, and concrete surfaces. For a bioretention facility or planter box, the BMP footprint area should be assumed to be impervious.

**85th Percentile Storm Depth** is used to compute the Stormwater Quality Design Volume (SQDV) per the Orange County Drainage Area Management Plan Exhibit 7.II, Model Water Quality Management Plan.

### **2.3.2. Outputs**

**BMP Footprint Area** is the area, in square feet, of the BMP at the overflow weir crest.

**BMP Capture Volume** is the storage capacity, in cubic feet, of the BMP below the overflow weir crest. This volume includes the air space above the media material, as well as the interstitial space in the media (i.e. gravel, choke stone, sand, plant media, and mulch).

**Total BMP Volume** is the storage capacity, in cubic feet, below the suggested freeboard elevation. Total BMP Volume is not viewed to be as crucial to flow duration control as the Capture Volume.

---

<sup>7</sup> Hydrologic Soil Group for a site can be found at <http://websoilsurvey.nrcs.usda.gov/app/websoilsurvey.aspx>.

**Orifice Diameter** is the size of the low flow control opening, in inches. The diameter is rounded to the nearest 1/32nd inch, so that standard drill bits can be used to create the orifice.

The last output provides a yes or no answer to the question, “Is the Hydromodification Capture Volume greater than the SQDV?” If the answer is “yes”, then the hydromodification BMP sizing outputs are appropriate. If the answer is “no” then the SQDV should be used in place of the Hydromodification BMP Capture Volume. For guidance on sizing treatment control BMPs, see Orange County Drainage Area Management Plan Exhibit 7.II, Model WQMP<sup>8</sup>.

### **2.3.3. Modifying the BMP Design Configuration**

If a project proponent wishes to modify the design configurations provided in Figures 1 through 4 while still using the spreadsheet tool to size the BMP, then the modified BMP shall meet the following criteria:

1. If the BMP allows for infiltration into the underlying soils (i.e. bioretention or vault with open bottom), then the footprint area at the bottom of the BMP shall be equal to or greater than the bottom footprint calculated using the sizing tool<sup>9</sup>.
2. The BMP Capture Volume stored below the overflow weir crest shall be equal to or greater than the capture volume calculated using the sizing tool.
3. The available freeboard height and storage above the overflow weir crest can be modified as long as the peak design discharge, required by the Orange County Local Drainage Manual (OCEMA 1996) and Hydrology Manual (OCEMA 1986) or the local permitting authority, can be properly conveyed.
4. If the full brim pressure on the bottom orifice is modified, then the low flow orifice diameter shall be modified such that the low flow threshold ( $0.1Q_2$ ) is conveyed at the new full brim pressure.

One example of a configuration modification is to reduce the depth of an underground vault with an open bottom. If the design depth is changed from 7 feet, as shown in Figure 2, to 4 feet, then the footprint area must increase to maintain the BMP Capture Volume. For this case the footprint must increase by at least 7/4 (1.75) times assuming the walls are vertical. Increasing the design depth beyond 7 feet in order to reduce the footprint, however, is not an allowable modification.

If the underground vault requires a low flow orifice, then the orifice diameter must increase such that the low flow threshold ( $0.1Q_2$ ) is conveyed at the reduced brim-full depth. For

---

<sup>8</sup> The SQDV will only be greater than the Hydromodification Capture Volume if the developed catchment has low imperviousness (2% to 4% or lower). Most Priority Development Projects are expected to have greater imperviousness than this threshold.

<sup>9</sup> For the bioretention facility, the bottom footprint area is the same as the top of media, which can be calculated assuming 3:1 side slopes dropping 1.5-ft from the overflow weir crest elevation to the top of mulch.

instance, assume the sizing tool computes the orifice diameter to be 3 inches for a brim-full depth of 6.5 feet. If the brim-full depth of the modified vault is 3.5 feet, then the modified low flow orifice diameter can be computed using the following formula<sup>10</sup>:

$$D_{\text{mod}} = D_{\text{tool}} [H_{\text{tool}}/H_{\text{mod}}]^{1/4}$$

Where:

$D_{\text{mod}}$  = modified low flow orifice diameter (inches)

$D_{\text{tool}}$  = calculated low flow orifice diameter from the sizing tool (inches)

$H_{\text{tool}}$  = assumed brim-full pressure head used in the sizing tool (feet)

$H_{\text{mod}}$  = modified brim-full pressure head (feet)

Using this formula for the example, the modified low flow orifice diameter ( $D_{\text{mod}}$ ) is 3-1/2 inches ( $3 * [6.5/3.5]^{1/4}$ ).

---

<sup>10</sup> This formula is derived from the orifice discharge equation provided in Appendix I.

## **Appendix I. Modeling Methodology**

**APPROACH**

BMP types were selected based on responses to a three question survey of the South Orange County cities, provided in Table A-1 below. The responses indicate that smaller, site-based BMPs were more likely to be implemented during the interim period than larger regional detention basins.

**Table A-1. BMP Survey Responses**

QUESTIONS	Municipality				
	Mission Viejo	Laguna Niguel	Dana Point	Lake Forest	San Juan Capistrano
1. What types of new development and redevelopment projects are anticipated which may need to use the interim hydromodification sizing tool?	Commercial	High Density Residential	Small Redevelopment	Residential, Commercial, Sports Park, & Playgrounds	Redevelopment
2. What is the range of project sizes that are anticipated in the next year or so? <sup>1</sup>	0.5 to 10.3 acres	2 acres	< 1 to 2.3 acres	60 to < 800 acres	1 to < 50 acres
3. What two types of structural BMPs would be most useful to have a design tool for?	Underground Detention Vault & Bioretention	Bioretention	Underground Detention Vault & Bioretention	Detention Pond, Detention Vault, Detention Pipe, & Bioretention	Detention Vault, Detention Pipe, Bioretention, Detention Domes, & Combined Bioretention and Vault

<sup>1</sup> Large project areas may need to be subdivided into multiple catchment areas.

**ASSUMPTIONS**

For each BMP type, ten continuous hydrologic simulations associated with a combination of two soil types (A/B and C/D) and five imperviousness values (1%, 25%, 50%, 75%, and 100%), were performed on a generic catchment area in order to generate long-term flow records. The generic catchment area was set to 1 acre to size the bioretention facility, 10 acres to size the underground vaults, and ¼ acre to size the planter box. These areas were used because they are between the expected lower and upper limits of catchment areas likely to drain into each BMP type. Bioretention facilities are expected to be applied to catchments ranging between 5,000 square feet (0.11 acres) to 5 acres, underground vaults are expected to be applied to catchments ranging between 1 acre and 50 acres, and planter boxes are expected to be applied to catchments less than 1 acre. While the 1% imperviousness simulation represents the baseline pre-development flow records, the 25%, 50%, 75%, and 100% simulations represent a range of post-development flow conditions. The BMPs were sized by iteratively adjusting the BMP footprint until flow duration control was achieved, as stipulated by the IHC for the minimum footprint allowable.

Geosyntec performed continuous simulations using US EPA’s Storm Water Management Model (SWMM). Stage-storage-discharge relationships were included in the post-development SWMM simulations so that the post-development flow records could be routed through the BMP being sized. Table A-2 below provides the key SWMM catchment parameters.

**Table A-2. Key SWMM Catchment Parameters**

PARAMETER	VALUE
Precipitation Gage	Trabuco
Area	1 acre (Bioretention) 10 acres (Underground Vault)
Catchment Slope	5 %
% Imperviousness	Pre-development: 1% Post-Development: 25%, 50%, 75%, & 100%
Depression Storage - Impervious	0.02 inches
Depression Storage - Pervious	0.10 inches
Infiltration Method	GREEN AMPT
Hydraulic Conductivity	Pre-Development A/B Soils: 0.30 inches/hour Post-Development A/B Soils: 0.23 inches/hour Pre-Development C/D Soils: 0.05 inches/hour Post-Development C/D Soils: 0.04 inches/hour

Detailed SWMM parameters are listed in Table A-3 below.

**Table A-3. Detailed SWMM Catchment Parameters**

PARAMETER	UNIT	VALUE A/B Soils	VALUE C/D Soils
<i>Subcatchment SWMM Parameters</i>			
Precipitation Gage	--	Trabuco	Trabuco
Outlet	--	N/A	N/A
Area	Acres	10, 1, 0.25	10, 1, 0.25
Width	Feet	660, 209, 104	660, 209, 104
% Slope	%	5	5
% Imperv	%	1, 25, 50 75, & 100	1, 25, 50 75, & 100
N-Imperv	--	0.012	0.012
N-Perv	--	0.15	0.15
Dstore-Imperv	Inches	0.02	0.02
Dstore-Perv	Inches	0.1	0.1
%Zero-Imperv	%	25	25
Subarea Routing	--	OUTLET	OUTLET
Percent Routed	%	100	100
Infiltration	Method	GREEN_AMPT	GREEN_AMPT
Suction Head	Inches	1.5	8
Undeveloped Conductivity	in/hr	0.3	0.05
Developed Conductivity	in/hr	0.23	0.04

PARAMETER	UNIT	VALUE A/B Soils	VALUE C/D Soils
Initial Deficit	Fraction	0.33	0.30
Groundwater	yes/no	NO	NO
<i>Climatology SWMM Parameters</i>			
Temperature	--	N/A	N/A
Evaporation	Monthly Averages	CIMIS Zone 4	CIMIS Zone 4
Wind Speed	--	N/A	N/A
Snow Melt	--	N/A	N/A
Areal Depletion	--	N/A	N/A
<i>Simulation Options</i>			
Infiltration Model	--	Green Ampt	Green Ampt
Routing Method	--	None	None
Reporting Time Step	Days:Hr:Min:Sec	1 hour	1 hour
Dry Weather Time Step	Days:Hr:Min:Sec	4 hours	4 hours
Wet Weather Time Step	Days:Hr:Min:Sec	15 minutes	15 minutes
Routing Time Step	Seconds	60	60
Dynamic Wave Inertial Terms	--	Dampen	Dampen
Define Supercritical Flow By	--	Both	Both
Force Main Equation	--	Hazen-Williams	Hazen-Williams
Variable Time Step Adjustment Factor	%	75	75
Conduit Lengthening	Seconds	0	0
Minimum Surface Area	Square Feet	0	0

Additional model parameters and assumptions include:

- **Precipitation Data:** The Trabuco precipitation record was used because the rainfall intensity is greater than that measured at the Laguna gage, the other long-term precipitation record in South Orange County. By using a more intense rainfall record, this results in more conservative BMP sizes.
- **Catchment Dimensions:** The assumed generic catchment width is square.
- **Slope:** A typical South Orange County terrain is assumed to have a 5% catchment slope.
- **Infiltration Parameters:** The assumed pre-development hydraulic conductivity is based on typical values associated with Soil Types A/B and C/D, as referenced in *SWMM Hydrology: Runoff and Service Modules* (James et al, 2002)<sup>11</sup>. The post-development hydraulic conductivity was assumed to be 75% of the pre-development hydraulic

<sup>11</sup> James W., Huber W.C., Pitt R.E., Dickinson R.E., James W.R.C. 2002. *SWMM Hydrology: Runoff and Service Modules*.

conductivity in order to account for disturbance and compaction. The post-development hydraulic conductivity was also used as the infiltration rate within the BMPs.

## **BMP CONFIGURATION ASSUMPTIONS**

### **Bioretention Facility Assumptions (Figure 1)**

- Low flow threshold = 10% of the 2-year pre-development flow rate ( $0.1Q_2$ )<sup>12</sup>.
- Infiltration rate into A/B soils = 0.23 inches/hour. Infiltration rate into C/D Soils = 0.04 inches/hour.
- Media storage capacity = porosity - field capacity. This assumes that only freely drained storage is considered. The storage capacity used for gravel and choke stone is 0.4, for sand and plant media is 0.26, and for mulch is 0.5.
- An underdrain and low flow orifice is used for C/D Soils, but not for A/B Soils.
- Low flow orifice is sized to discharge the low flow threshold at the head associated with the overflow weir elevation (C/D Soils only)<sup>13</sup>.
- Slotted underdrain pipe capacity and infiltration rate through media is significantly greater than the low flow threshold of  $0.1Q_2$  (C/D Soils only).
- Overflow weir crest length is sized to convey the peak design flowrate determined from the Orange County flood control standards<sup>14</sup>.
- Slotted underdrain pipe invert and low flow orifice @ 0.5-ft from bottom of facility (C/D Soils only).
- Top of Media @ 4.75-ft from bottom of facility.
- Vertical walls between the bottom of facility and top of media.
- 3:1 side slopes above top of media.
- Overflow weir @ 6.25-ft from bottom of facility.
- 0.5-ft of freeboard above overflow weir.

### **Underground Vault with Open Bottom Assumptions (Figure 2)**

- Low flow threshold = 10% of the 2-year pre-development flow rate ( $0.1Q_2$ ).

---

<sup>12</sup>  $0.1Q_2$  was determined by constructing a partial-duration series as follows. For the entire runoff time series generated by the model, the runoff time series was divided into a set of discrete events. Flow events were considered separate when the flow rate dropped below a threshold value of 0.002 cfs/acre for a period of at least 24 hours. The peak flow was determined for each event and ranked to establish the 2 year return frequency.

<sup>13</sup> Discharge from an orifice is calculated using the equation  $Q = 3.78 D^2 H^{1/2}$  where:  
Q = discharge (cfs); D = diameter (ft); H = head above the orifice center (ft).

<sup>14</sup> Discharge from a rectangular weir is calculated using the equation  $Q = 3.33 L H^{1.5}$  if the weir is suppressed and  $Q = 3.33 (L - 0.2H) H^{1.5}$  if the weir is contracted where:  
Q = discharge (cfs), L = crest length (ft); H = head above weir crest (ft).

- Infiltration rate into A/B soils = 0.23 inches/hour. Infiltration rate into C/D Soils = 0.04 inches/hour.
- Low flow orifice is included for C/D Soils, not for A/B Soils.
- Low flow orifice is sized to discharge the low flow threshold at the head associated with the overflow weir elevation (C/D Soils only).
- Overflow weir crest length is sized to convey the peak design flow rate determined from Orange County flood control standards.
- Low flow orifice discharge @ 0.5-ft from bottom of facility (C/D Soils only).
- Vertical walls throughout.
- Overflow weir @ 7.0-ft from bottom of facility.
- 1.0-ft of freeboard above overflow weir.

#### **Underground Vault with Closed Bottom Assumptions (Figure 3)**

- Low flow threshold = 10% of the 2-year pre-development flow rate ( $0.1Q_2$ ).
- No infiltration into soils.
- Low flow orifice is included for C/D and A/B Soils.
- Low flow orifice is sized to discharge the low flow threshold at the head associated with the overflow weir elevation.
- Overflow weir crest length is sized to convey the peak design flow rate determined from Orange County flood control standards.
- Low flow orifice discharge is located at same elevation as the bottom of vault. (Note: sediment storage capacity should be provided below the low flow orifice plate as shown on Figure 3; this can be accomplished by placing the outlet structure in a separate manhole or lowering the vault floor below the outlet. Any added storage below the outlet does not count towards the BMP Capture Volume.)
- Vertical walls throughout.
- Overflow weir @ 7.0-ft from bottom of facility.
- 1.0-ft of freeboard above overflow weir.

#### **Planter Box Assumptions (Figure 4)**

- Low flow threshold = 10% of the 2-year pre-development flow rate ( $0.1Q_2$ ).
- No infiltration into soils.

- Media storage capacity = porosity – field capacity. This assumes that only freely drained storage is considered. The storage capacity used for gravel and choke stone is 0.4, for sand and planting media is 0.26, and for mulch is 0.5.
- An underdrain and low flow orifice is used for C/D and A/B Soils.
- Low flow orifice is sized to discharge the low flow threshold at the head associated with the overflow weir elevation.
- Slotted underdrain pipe capacity and infiltration rate through media is significantly greater than the low flow threshold of  $0.1Q_2$ .
- Overflow weir crest length is sized to convey the peak design flowrate determined from the Orange County flood control standards.
- Slotted underdrain pipe invert and low flow orifice @ bottom of facility.
- Top of Media @ 4.25-ft from bottom of facility.
- Vertical walls throughout.
- Overflow weir @ 5.25-ft from bottom of facility.
- 0.25-ft of freeboard above overflow weir.

## **RESULTS**

Figures A-1 through A-8 below provide the flow duration curves for all forty SWMM simulations (2 soil types x 4 BMP types x 5 imperviousness values), which demonstrate that the IHC is met. The IHC is met because the flow duration curve for the post-development condition with BMPs is below the pre-development (naturally-occurring) condition within the flow limits specified ( $0.1Q_2$  to  $Q_{10}$ ).

In evaluating the proportions of runoff exiting the modeled BMPs, it was confirmed that the modeled hydromodification BMPs meet the 80% runoff capture goal for treatment<sup>15</sup>, as shown in Table A-4 below.

---

<sup>15</sup> It was assumed that BMPs, which allow infiltration (bioretention and underground vault w/ open bottom) and are placed in C/D soils, do require biotreatment, via a low flow orifice, in order to feasibly achieve 80% runoff capture. BMPs, which allow infiltration and are in areas with A/B soils, do not need biotreatment to achieve 80% runoff capture. BMPs, which do not allow infiltration (underground vault with closed bottom and planter box), do require biotreatment, via a low flow orifice, in order to feasibly achieve 80% runoff capture.

**Table A-4. Proportions of Runoff Exiting the BMPs**

<b>BMP Type</b>	<b>Soil Type</b>	<b>Imperviousness (%)</b>	<b>Infiltrated Runoff (%)</b>	<b>Runoff Routed Through Orifice (%)</b>	<b>Bypassed Runoff (%)</b>	<b>Captured Runoff (%)</b>	<b>Goal Met for 80% Capture (yes/no)</b>
Bioretention	C/D	100	18.0	75.0	7.1	92.9	Yes
Bioretention	C/D	75	13.8	77.6	8.6	91.4	Yes
Bioretention	C/D	50	14.6	75.4	9.9	90.1	Yes
Bioretention	C/D	25	15.1	71.0	14.0	86.0	Yes
Bioretention	A/B	100	98.0	N/A	2.0	98.0	Yes
Bioretention	A/B	75	97.2	N/A	2.8	97.2	Yes
Bioretention	A/B	50	96.7	N/A	3.3	96.7	Yes
Bioretention	A/B	25	93.1	N/A	6.9	93.1	Yes
Vault-Open	C/D	100	20.3	74.7	5.0	95.0	Yes
Vault-Open	C/D	75	17.5	75.6	6.8	93.2	Yes
Vault-Open	C/D	50	18.7	73.7	7.6	92.4	Yes
Vault-Open	C/D	25	14.6	72.0	13.4	86.6	Yes
Vault-Open	A/B	100	98.2	N/A	1.8	98.2	Yes
Vault-Open	A/B	75	97.8	N/A	2.2	97.8	Yes
Vault-Open	A/B	50	96.4	N/A	3.6	96.4	Yes
Vault-Open	A/B	25	94.6	N/A	5.4	94.6	Yes
Vault-Closed	C/D	100	N/A	93.8	6.2	93.8	Yes
Vault-Closed	C/D	75	N/A	93.0	7.0	93.0	Yes
Vault-Closed	C/D	50	N/A	92.2	7.8	92.2	Yes
Vault-Closed	C/D	25	N/A	86.3	13.7	86.3	Yes
Vault-Closed	A/B	100	N/A	98.4	1.6	98.4	Yes
Vault-Closed	A/B	75	N/A	98.0	2.0	98.0	Yes
Vault-Closed	A/B	50	N/A	97.4	2.6	97.4	Yes
Vault-Closed	A/B	25	N/A	96.2	3.8	96.2	Yes
Planter Box	C/D	100	N/A	92.6	7.4	92.6	Yes
Planter Box	C/D	75	N/A	91.8	8.2	91.8	Yes
Planter Box	C/D	50	N/A	91.0	9.0	91.0	Yes
Planter Box	C/D	25	N/A	89.1	10.9	89.1	Yes
Planter Box	A/B	100	N/A	97.7	2.3	97.7	Yes
Planter Box	A/B	75	N/A	97.7	2.4	97.7	Yes
Planter Box	A/B	50	N/A	97.3	2.7	97.3	Yes
Planter Box	A/B	25	N/A	96.2	3.8	96.2	Yes

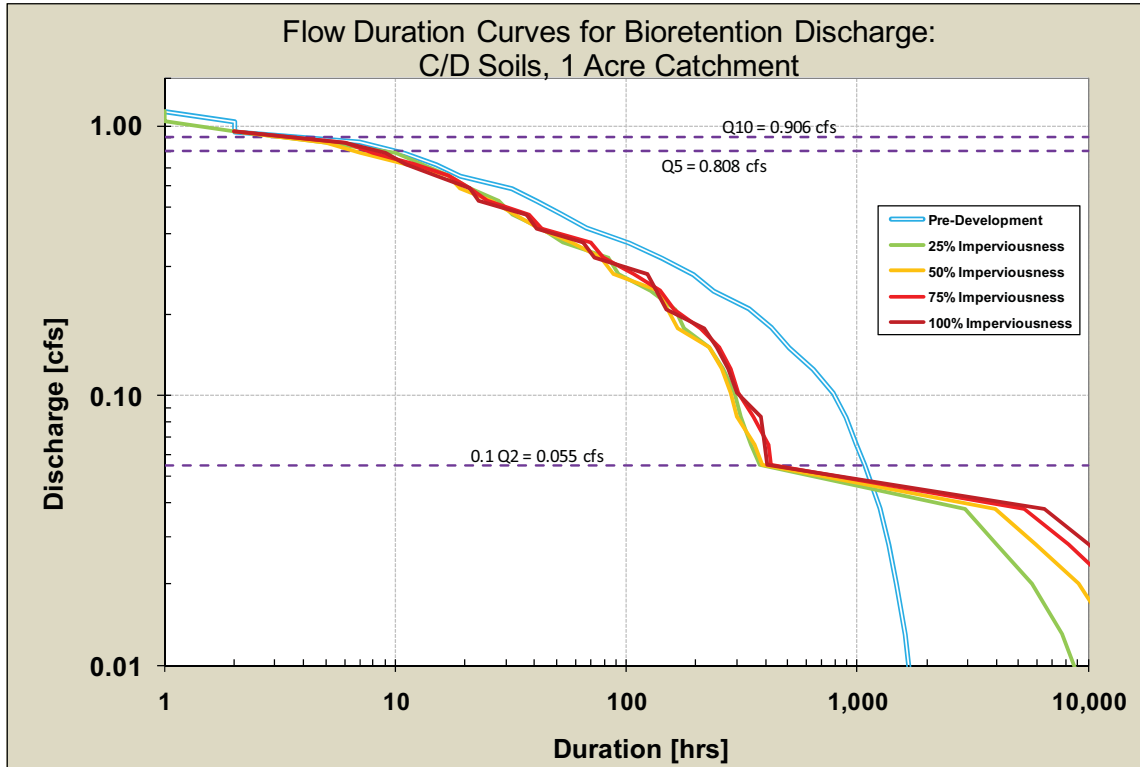

Figure A-1. Flow Duration Results for Bioretention BMP with C/D Soils

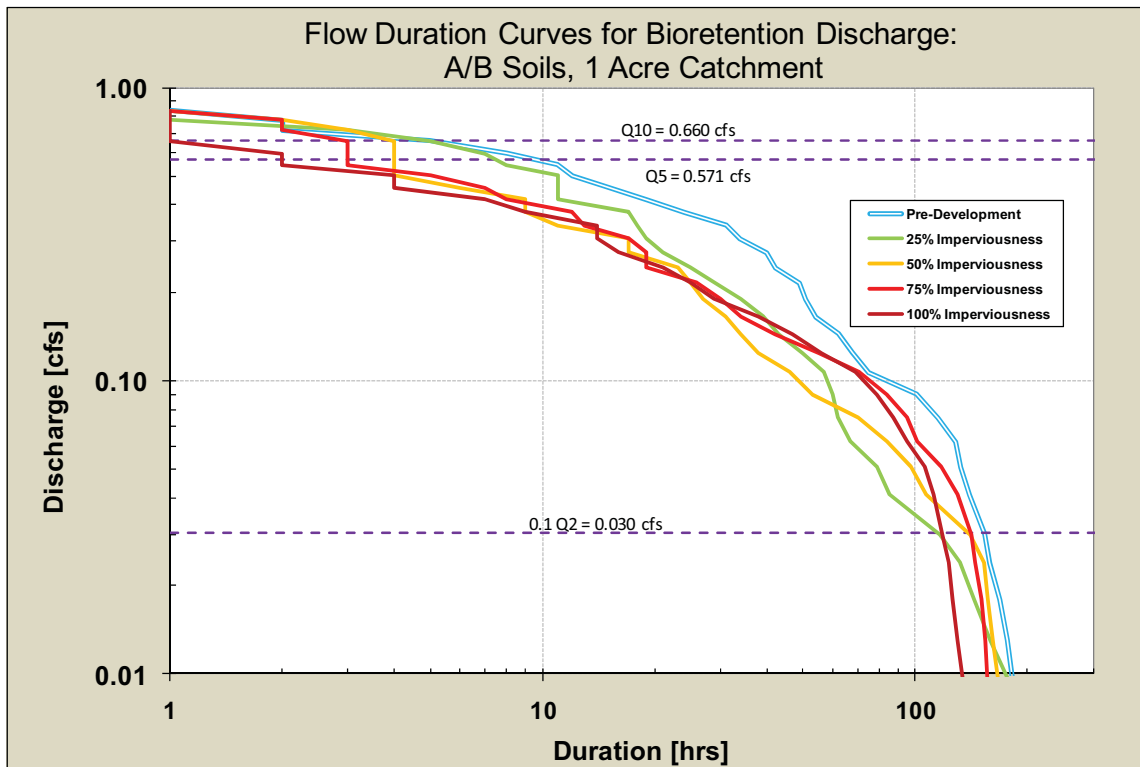

Figure A-2. Flow Duration Results for Bioretention BMP with A/B Soils

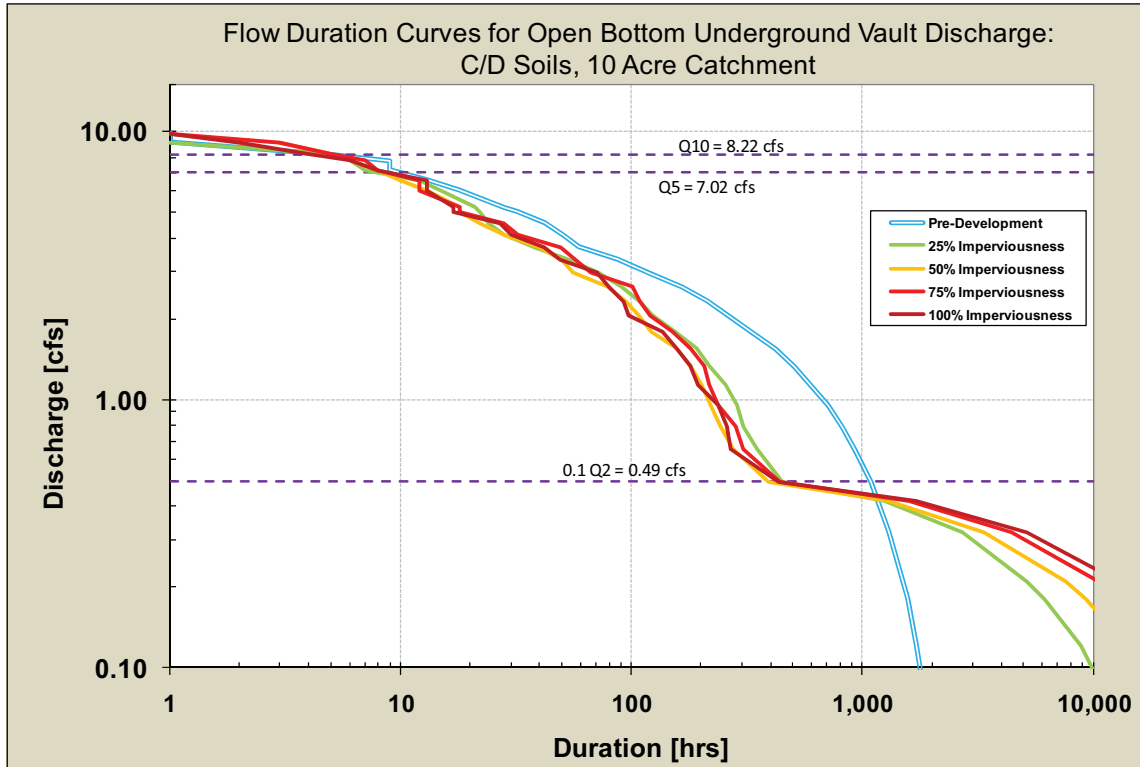

Figure A-3. Flow Duration Results for Open Bottom Underground Vault BMP with C/D Soils

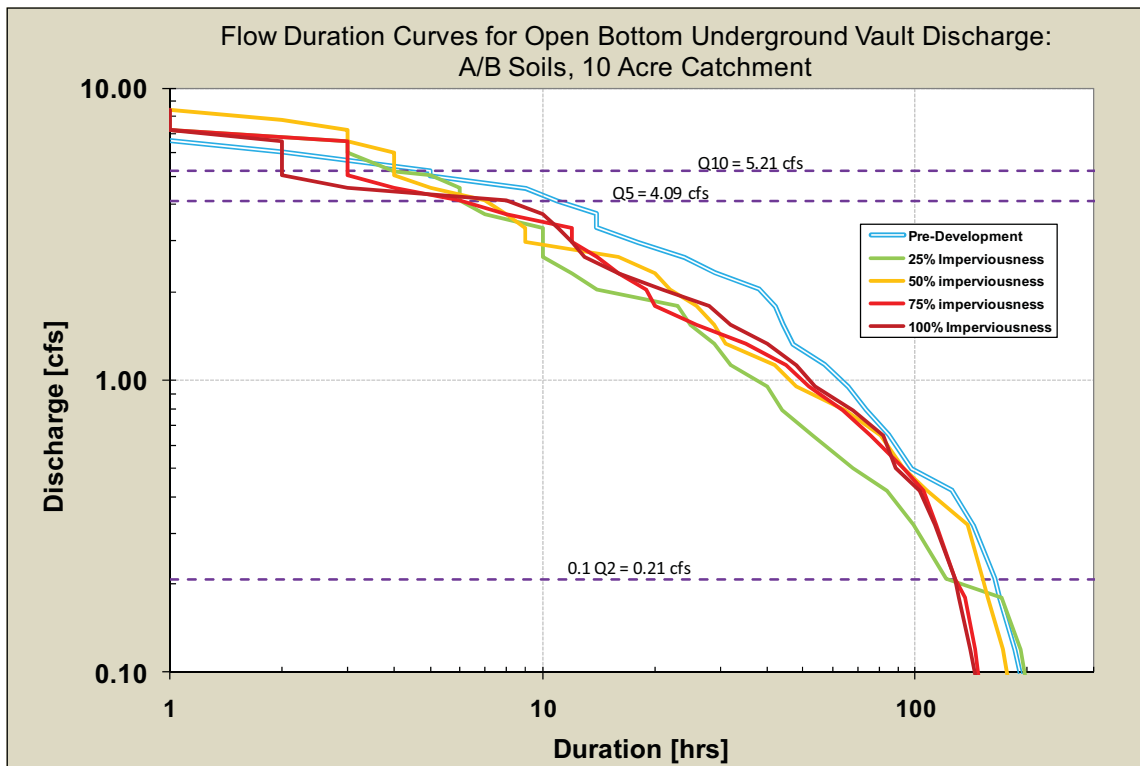

Figure A-4. Flow Duration Results for Open Bottom Underground Vault BMP with A/B Soils

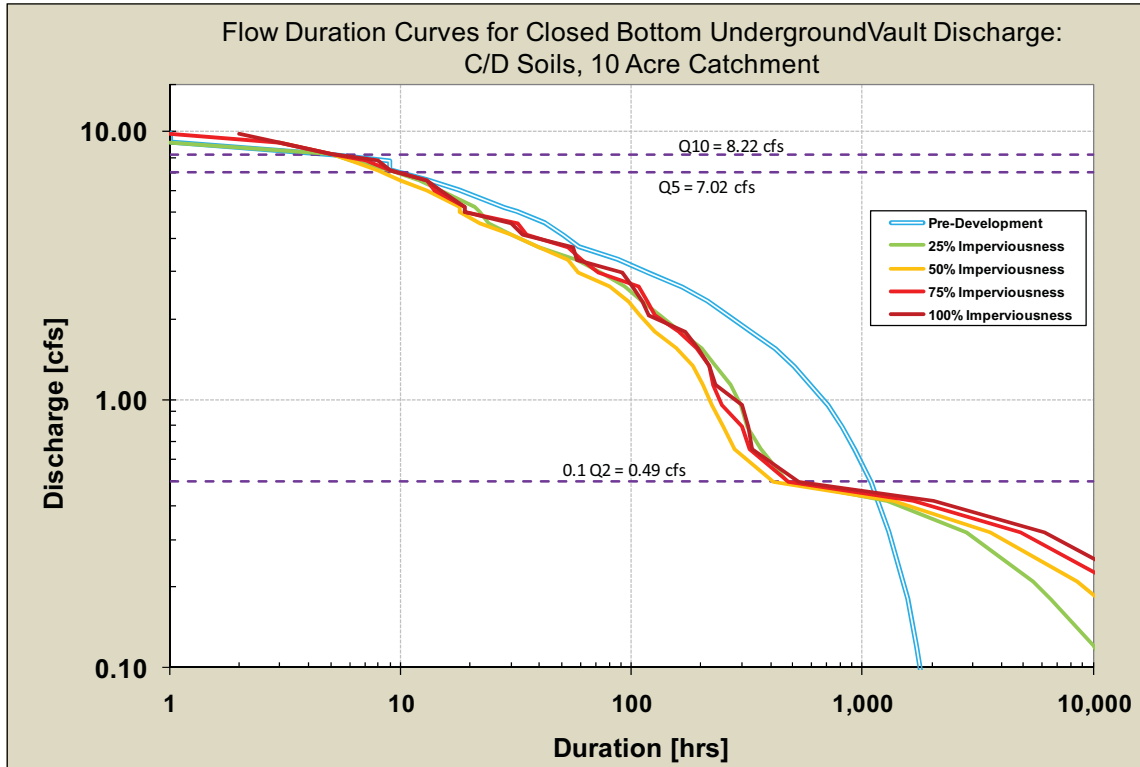

Figure A-5. Flow Duration Results for Closed Bottom Underground Vault with C/D Soils

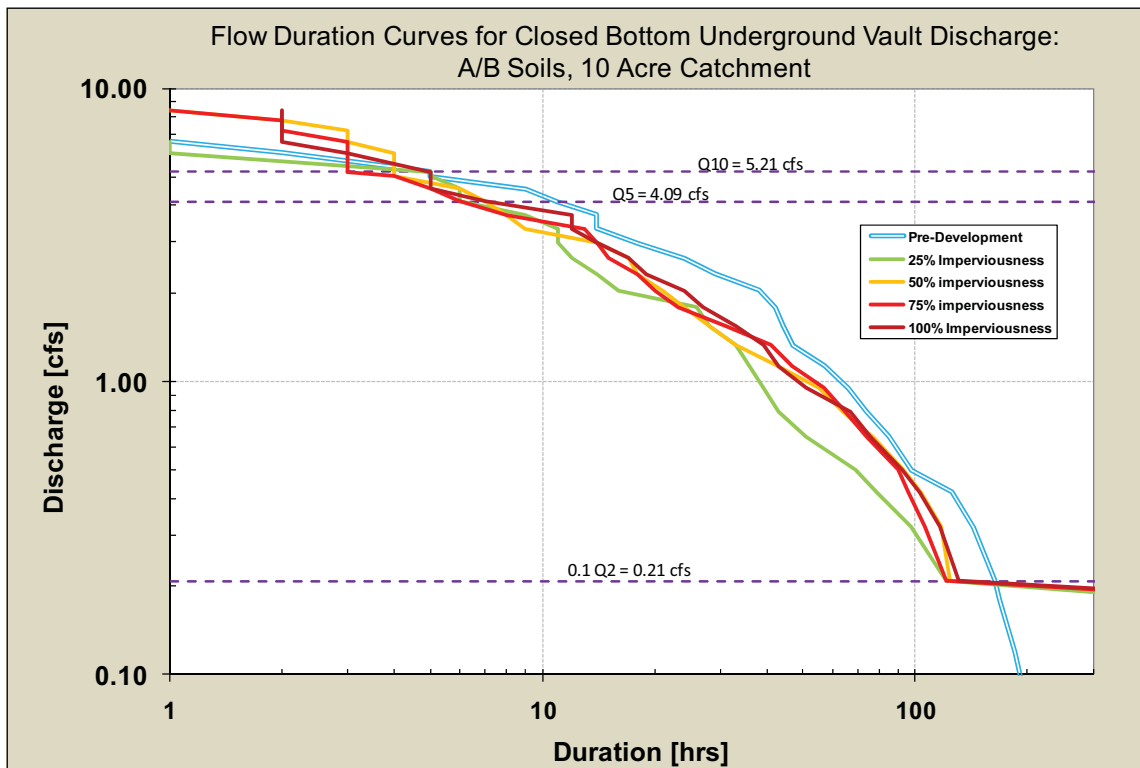

Figure A-6. Flow Duration Results for Closed Bottom Underground Vault with A/B Soils

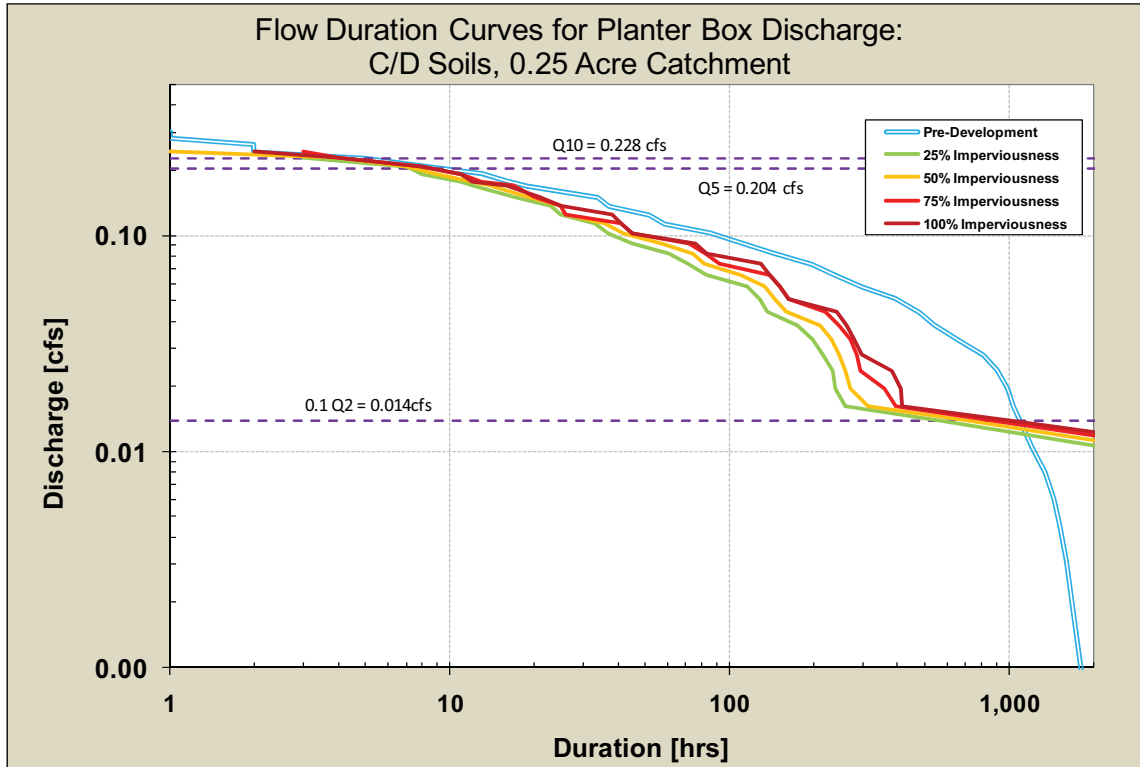

Figure A-7. Flow Duration Results for Planter Box BMP with C/D Soils

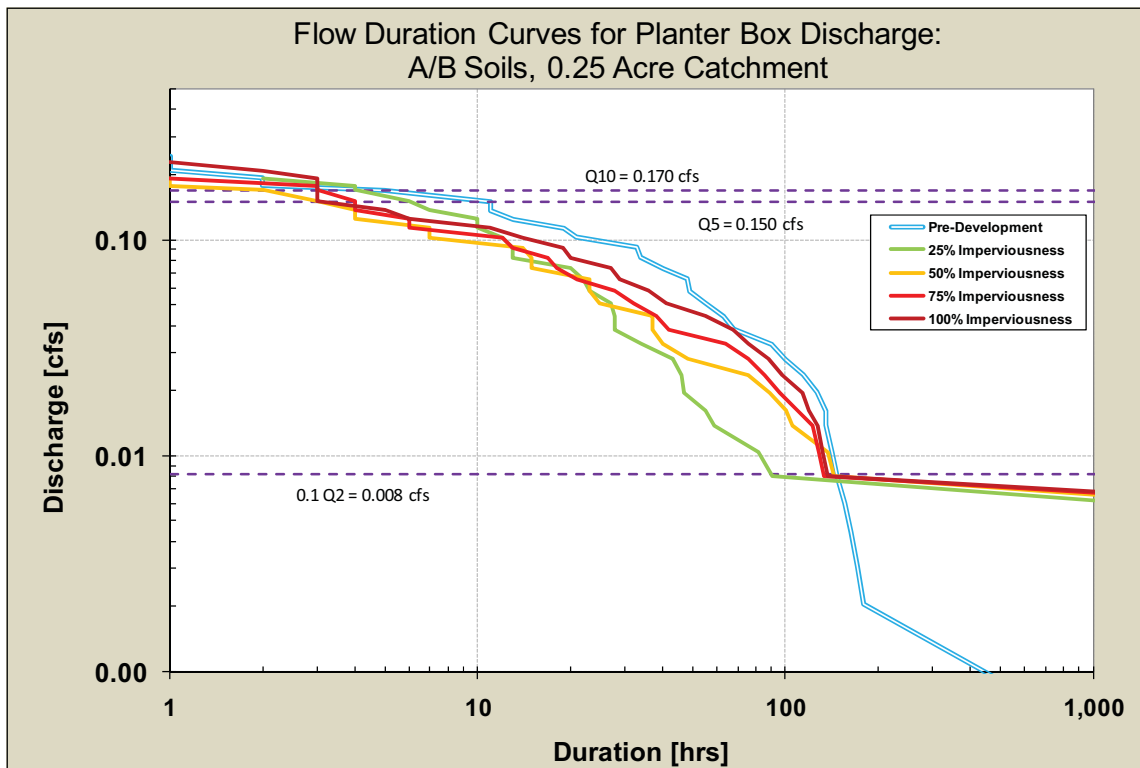

Figure A-8. Flow Duration Results for Planter Box BMP with A/B Soils